

Canopy Mini Pure'line 60 cm White

EAN 5414425008117



Energy label

▪ Energy Efficiency class (EEIhood)	A
▪ Annual Energy Consumption (kWh/year) (AEChood)	36,3
▪ Fluid Dynamic Efficiency class (FDEhood)	A
▪ Lighting Efficiency class (LEhood)	A
▪ Grease Filtering Efficiency class (GFEhood)	D

Functions & features

▪ Control method	Remote control + Push buttons
▪ Number of speeds	3 + power
▪ Automatic Power revert (minutes)	6
▪ Motor	Integrated
▪ Sound absorber	Integrated
▪ Recirculation	Optional
▪ InTouch function	Standard
▪ Auto stop	▪
▪ Delayed switch off (minutes)	10
▪ Number of grease filters	1
▪ Grease filter	609014
▪ Grease filter cleaning indication	▪
▪ Recirculation filter cleaning indication	▪

Dimensions

▪ Product dimensions (WxDxH) (mm)	560 x 301 x 330
▪ Width flange (mm)	10
▪ Dimensions cut-out opening (WxD) (mm)	545 x 286
▪ Min dimensions cabinet (WxDxH) (mm)	x x
▪ Advised mounting height induction hobs (Hmin-Hmax) (mm)	-
▪ Advised mounting height gas hobs (Hmin-Hmax) (mm)	650 - 750
▪ Advised mounting height ceramic hobs (Hmin-Hmax) (mm)	600 - 750
▪ Diameter outlet (mm)	150
▪ Position exhaust	Right, Top, Left, Back, Front

Lighting

▪ Functional lighting type	Led
▪ Dimmable light	▪
▪ Soft-ON/OFF	▪
▪ Total energy consumption functional light (W)	8
▪ Color functional light	2700/4000

Airflow and noise level

- Airflow (m³/h) measured according to EN 61591
- Sound regulation according to EN 60704-2-13

Airflow and noise level

▪ Airflow speed 1 (m ³ /h) / Max Pressure speed 1 (Pa)	210 / 67
▪ Airflow speed 2 (m ³ /h) / Max Pressure speed 2 (Pa)	353 / 237
▪ Airflow speed 3 (m ³ /h) / Max Pressure speed 3 (Pa)	469 / 380
▪ Airflow Powerspeed (m ³ /h) / Max Pressure Powerspeed (Pa)	576 / 380
▪ Sound power speed 1 (dB(A)) / Sound pressure speed 1 (dB(A))	35 / 25
▪ Sound power speed 2 (dB(A)) / Sound pressure speed 2 (dB(A))	50 / 38
▪ Sound power speed 3 (dB(A)) / Sound pressure speed 3 (dB(A))	57 / 46
▪ Sound Powerspeed (dB(A)) / Sound pressure Powerspeed (dB(A))	61 / 49

Technical specifications

▪ Maximum power	119
▪ Voltage (V)	220-230
▪ Frequency (Hz)	50
▪ Length power supply cord (m)	1,3
▪ Power consumption in stand-by-mode (Ps) (W)	0.3

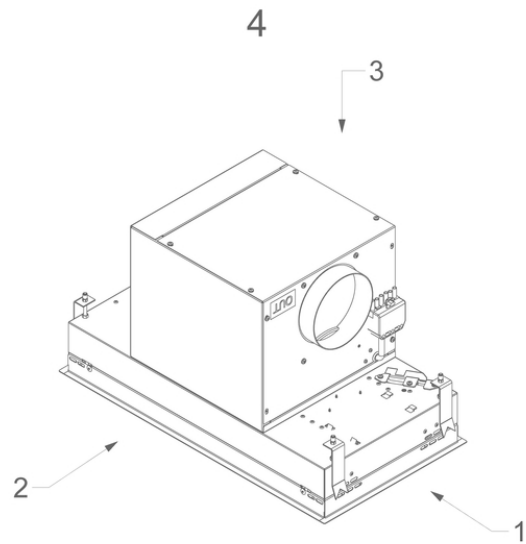
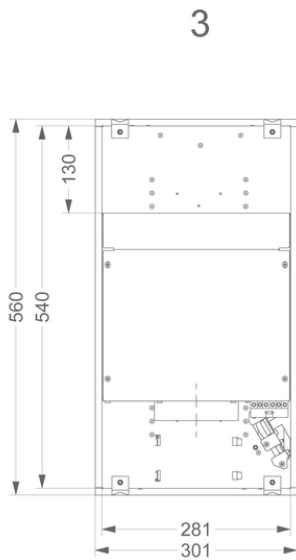
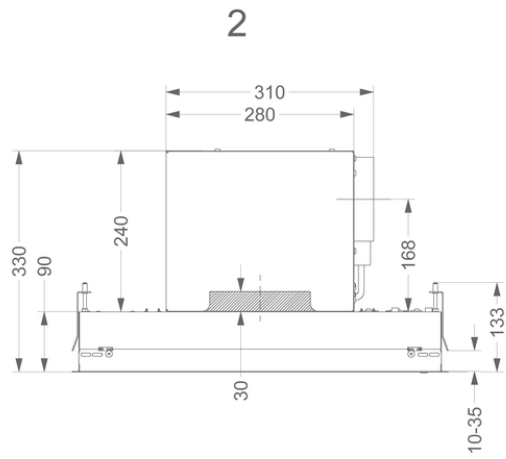
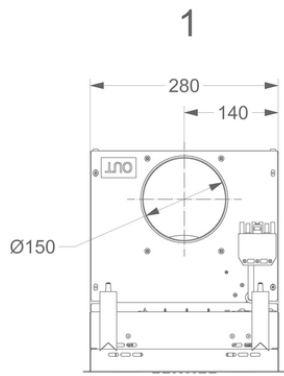

Installation accessories

Dissociated motor

- 800994

Kit to place motor at distance Mini Pure'line 810, 811 (≥V15)

Extension cable

- 700094

Extension cable 5 m

Accessories

Recirculation kit



811400

Recirculation set Mini Pure'line 810, 811 (370x149x20mm)

Recirculation box



830400

recirculation box with monoblock stainless steel (270x500mm)



831400

recirculation box with monoblock white (270x500mm)



7900400

Recirculation box with monoblock stainless steel, height 140 mm

Control kit



990030

Control kit for external lighting or valve

Efficiency Curve

